

Data Sheet



Helping Engineer the Technology of Power

ICE Components, Inc.

Tel 678-560-9172 Fax 678-560-9304

cust.serv@icecomp.com

www.icecomponents.com

1165 Allgood Rd., Ste. #20, Marietta, GA 30062

General Information

Customer	
Part Number	IN08070
Revision	0
Description	Inductor
Date	AUG-07-2009
Reference	--
Doc Control #	--
Issue(For ICE use only)	--

Mechanical Drawing

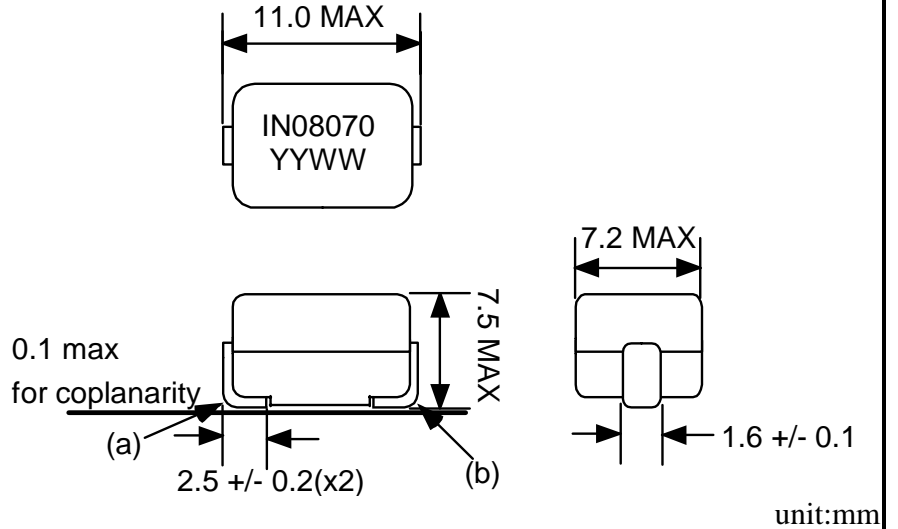

Specification

Sample Test Data

Item	Pins	Spec	Test Condition	Sample Test Data
Inductance @0Adc	S - F	220 nH +/- 10%	1 MHz, 0.1Vrms, series	
Inductance @Isat at 25degC	S - F	158 nH min	1 MHz, 0.1Vrms, series (47 Adc)	
DCR	S - F	0.29 mOhm +/- 10%	+25 deg C	
Isat at 25degC	S - F	47 Adc max		
Isat at +125degC	S - F	39 Adc max		
Idc	S - F	45 Adc max		

Schematic

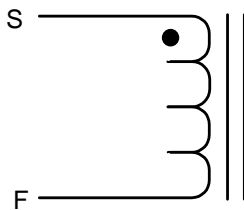

Recommended PCB Layout

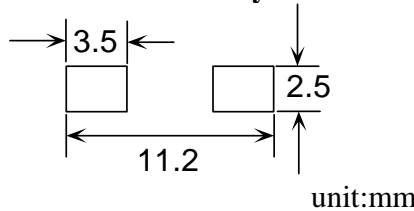

Remark

1. Isat is the current at which the inductance drops by 20%.
2. Idc is the current at which the temperature of the part increases by 50 deg C.
3. Inductance vs. Current Curve and Temperature vs. Current Curve as attached.
4. The nominal DCR is measured from point (a) to point (b), as shown on the mechanical drawing.
5. This is RoHS compliant product.
6. The max operating temperature is 130degC (ambient + temperature rise).

Sample approval is required before release to production. Sample specifications take precedence over customer specifications.

Customer Signature

Rev.	Description	PRD	CHK	APP	Date	NTFY
0	Initial release	Emily	Gary	L. L. Chou	2009/8/7	2009/8/7

P/N: IN08070

Inductance vs. Current

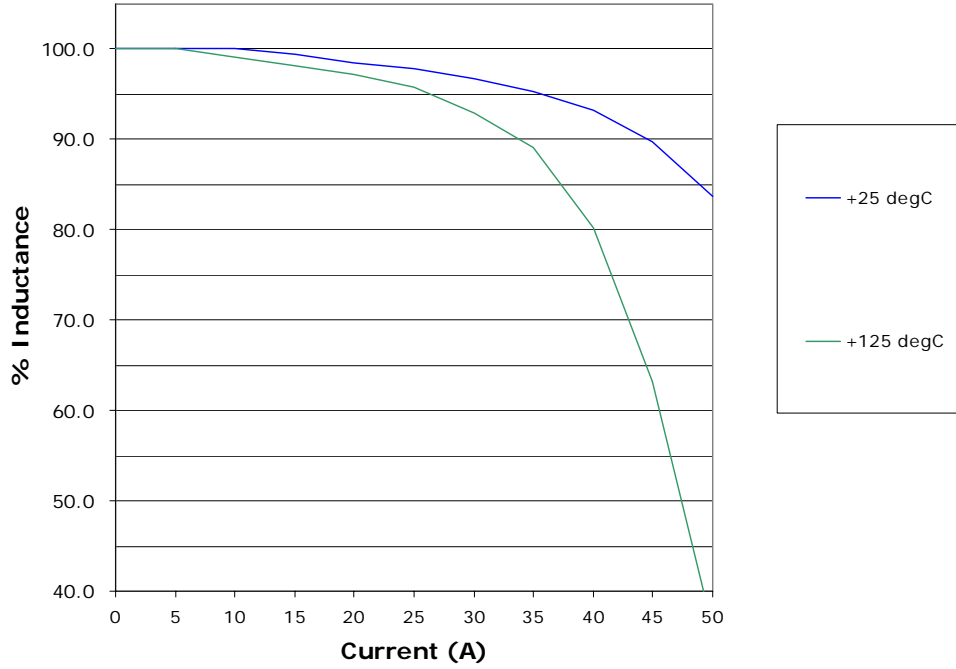

Temperature VS Current

